

BLDG # 1
Style/Stories 1.5 1 1/2 Story
Class of Const. 010 01.0
Building Use 0100 Single Fami
Exterior Wall 1 100 Frame
Exterior Wall 2 000 N/A
Basement 01 Typical
Garage/Cpt/Pav 00 N/A
Finished Attic 00 N/A
Porches 04 Enc Fr Prch
Deck/Balc/Stoop 00 N/A
AirConditioning 01 Combined Du
Fireplace 00 N/A
Extra Fireplace 00 N/A
Fixtures 0005 05 Fixtures
Room Count 00
Bedroom Count 00
Actual Year Blt 1920
Eff. Year Built 1935
Normal Depr Tbl FR FAIR
Functional Obs. 000
Economic Obs. 000
Observed Cond. 000
Obs. Cond. Code
Manufactured Hm 0000
Comm First Flr
Comm Upper Flr
Comm Wall Ratio 000 N/A

TAYLORVILLE 62568
Site Address: 000414 E PARK ST

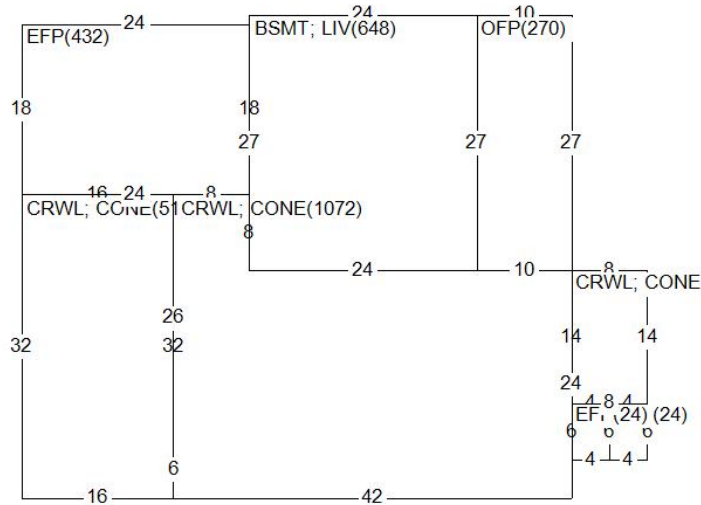

Effective Area 2,174

| BOOK | PAGE | DATE | QS | SALE PRICE |
|------|------|------|----|------------|
|------|------|------|----|------------|

| PERMIT NO | TYPE | DATE | AMOUNT |
|-----------|------|------|--------|
| R-1-27-12 | NC | 0512 | 700 |
| R-1-55-11 | NC | 1111 | |

Appraiser KZ
Appr Date 08/15/17
Use Code 0061 Commercial
NBHD 17.00 TAYLORVILLE
L222 M222 B222

| AREA | FLAT | EFF% | E/AREA | ACT% | A/AREA | EA/AA | HEATED |
|------|------|------|--------|------|--------|-------|--------|
| OFF | 294 | 1.00 | 294 | 1.00 | 294 | 294 | |
| BSMT | 648 | 1.00 | 648 | 1.00 | 648 | 648 | |
| LIV | 648 | 1.00 | 648 | 1.00 | 648 | 648 | 648 |
| CRWL | 1696 | 0.00 | 0 | 1.00 | 1696 | 0 | |
| CONE | 1696 | 0.90 | 1526 | 1.00 | 1696 | 1526 | 1696 |
| EFP | 456 | 1.75 | 798 | 1.00 | 456 | 798 | |

History Values
Tax Year Total Appraised Value
99 57,500
95 44,380

| MISC BLDG CODE | DESC | LENGTH | WIDTH | UNITS | EYB DT |
|----------------|-------|--------|-------|-------|---------|
| 1 2 | FENCE | .00 | .00 | 1.00 | 2011 AV |

| LAND LUSE DESC | ZONING | UNITS TP | ADJUSTMENT CODES |
|-------------------|--------|----------|------------------|
| 1 0061 COMMERCIAL | C1 | 80.10 F | DP |